

# G8 JHP HSV Sport gauges installation instructions.

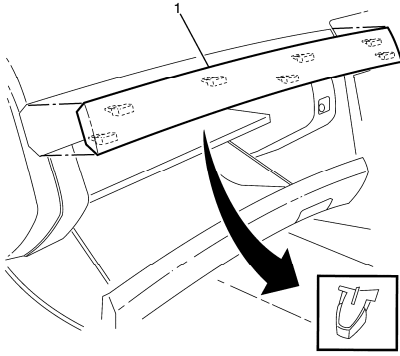

## Step 1. Instrument Panel Trim Panel removal



1. Using a suitable tool disengage the trim panel (1) retaining clips.
2. Remove the trim panel (1) from the I/P pad.
3. repeat for opposite side

## Step 2. Instrument Panel Outer Trim Cover removal

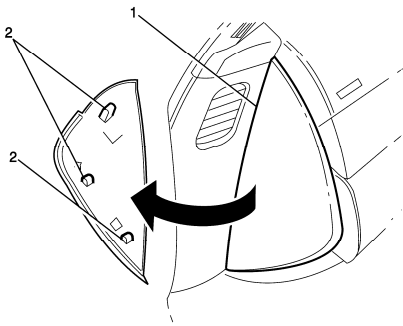

1. Grasp the lower area of the instrument panel outer cover (1) and carefully pull to disengage the retaining clips (2). The left side is shown, the right side is similar.
2. Remove the instrument panel outer cover (1) rotating upwards to disengage remaining clip (2). **(it is not necessary to remove the cover, you can just leave it open as shown on the picture on the right)**

## Step 3. Instrument Panel Insulator Panel removal - Right Side and Left Side

### RIGHT

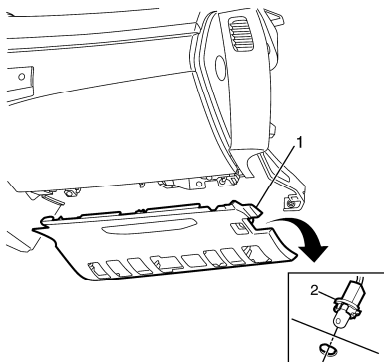

1. Grasp the instrument panel (I/P) insulator panel (1) and carefully pull downward to disengage the retaining clips.

2. Remove the courtesy lamp socket assembly (2) from the I/P insulator panel by turning the socket counter-clockwise. (not an option on G8)
3. Remove the I/P insulator panel (1).

## LEFT

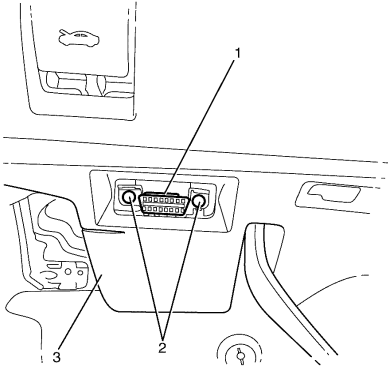

1. Remove the diagnostic plug to I/P lower trim plate assembly retaining screws (2).
2. Remove the diagnostic plug (1) from the I/P lower trim plate assembly (3).

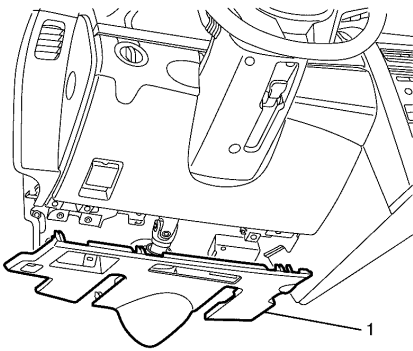

3. Grasp the I/P lower trim plate assembly (1) and carefully pull downward to disengage the retaining clips.
4. Remove the I/P lower trim plate assembly (1).

## Step 4. Instrument Panel Compartment removal

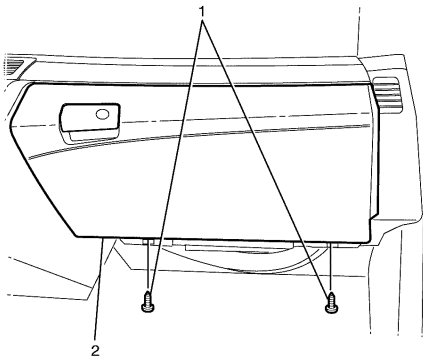

1. Remove the I/P compartment assembly lower retaining screws (1).
2. Open the I/P compartment assembly door (2).

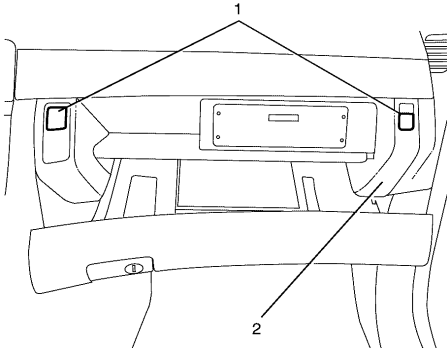

3. Remove the I/P compartment retaining screw covers (1) from the I/P compartment (2).

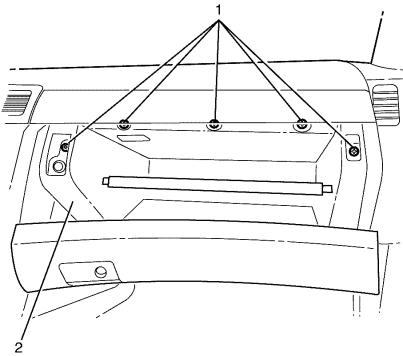

4. Remove the I/P compartment upper retaining screws (1).

5. Remove the I/P compartment (2).

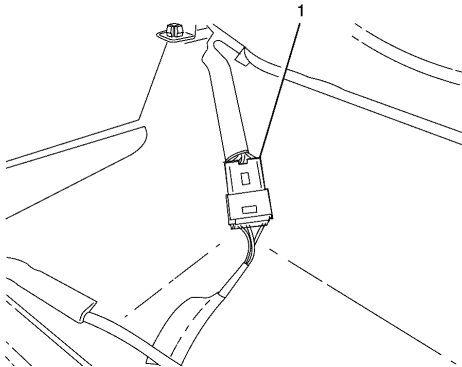

6. Disconnect the I/P compartment electrical connector (1) from the I/P compartment wiring harness.

### Step 5. Knee Bolster removal

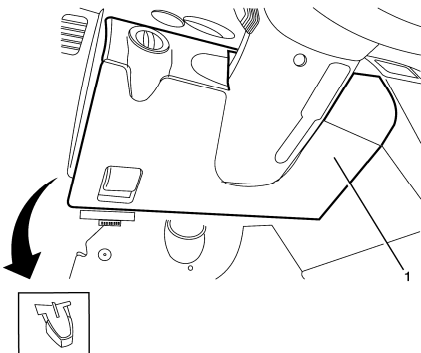

**Important:** When removing the knee bolster, care must be taken not to scratch the steering column cover. This can be achieved by slightly bending the knee bolster to avoid contact with the steering column.

1. Grasp the knee bolster assembly (1) and carefully pull downward to disengage the retaining clips.

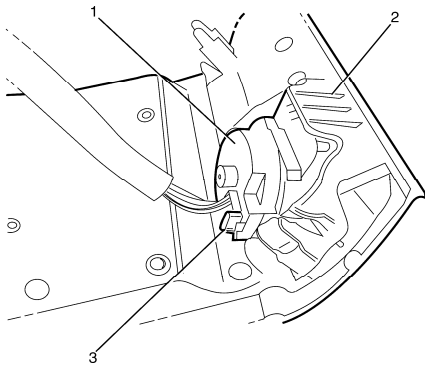

2. Disconnect the headlamp switch (1) electrical connector (3) from headlamp switch.
3. Remove the knee bolster (2).

## Step 6. Driver Information Display removal

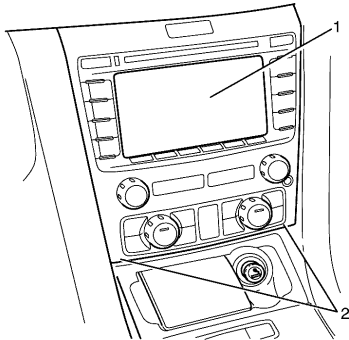

1. Grasp the bottom of the infotainment fascia (1) with both hands at point (2) and pull away from the instrument panel, disconnecting the fascia retainers.
2. Remove the infotainment fascia (1) from the infotainment unit.

## Step 7. Instrument Panel Extension removal

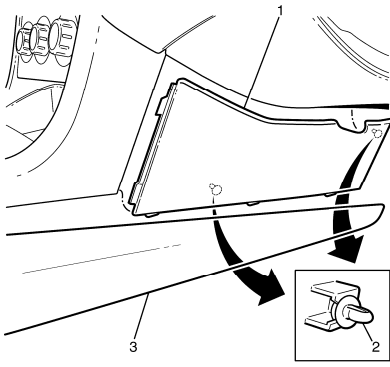

1. Disengage the I/P extension panel (1) to I/P carrier retaining clips (2).
2. Remove the I/P extension panel (1) from the centre console side trim panel (3).

### Step 8. Radio removal

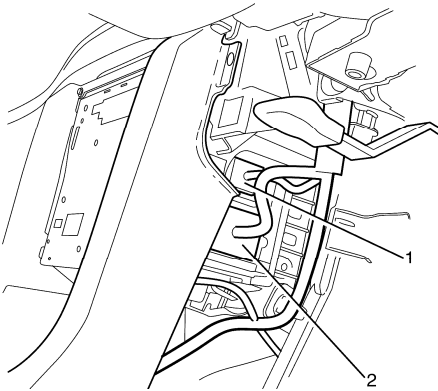

**Important: Make sure to release the retaining lever on the infotainment electrical connector (2) before disconnecting.**

1. Disconnect the connector(s) (1 and 2 where applicable) from the right side of the infotainment unit.

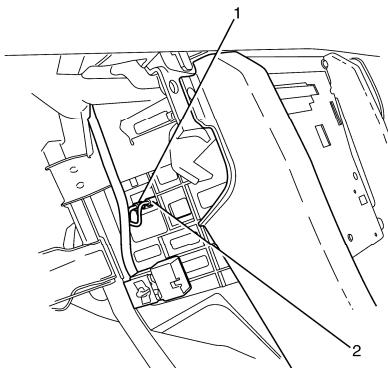

**Important: To disconnect coaxial connections, pinch down on the retaining clip near connection side of unit and push connector into the unit and slide connector away from the infotainment unit.**

**Important: Do not remove by pulling on the coaxial cables as they will be dislodged from the connector.**

2. Disconnect the connector(s) (1 and 2 where applicable) from the left side of the infotainment unit.

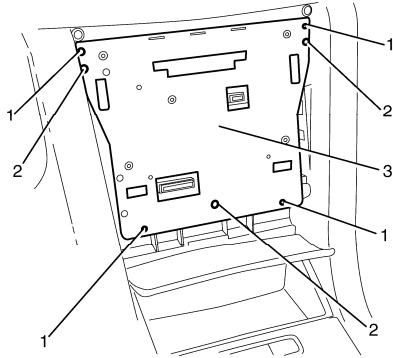

3. Remove the infotainment unit to instrument panel retaining screws (1).  
**Important:** Observe position of aligning lugs (2).
4. Remove the infotainment unit (3) from the instrument panel.

### Step 9. Console Trim Plate removal

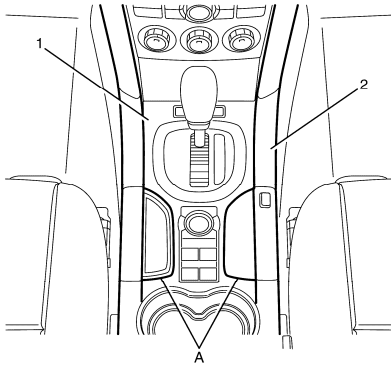

**Important:** The front floor console front cover (1) is retained by clips.

1. Grasp the front floor console front cover (1) at (A) and pull upwards to disengage the retaining clips from the floor console (2).

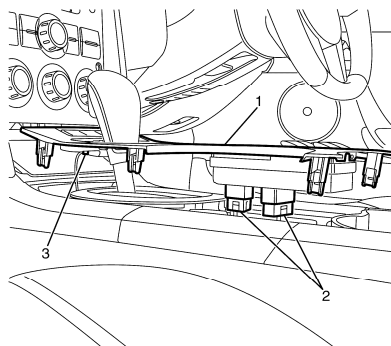

2. Disconnect the window and exterior mirror switch electrical connector (2).
3. Disconnect the Traction Control/ESP and Power switch (if fitted) electrical connectors (3).
4. Remove the front floor console front cover (1).

## Step 10. Instrument Panel Center Trim Panel removal

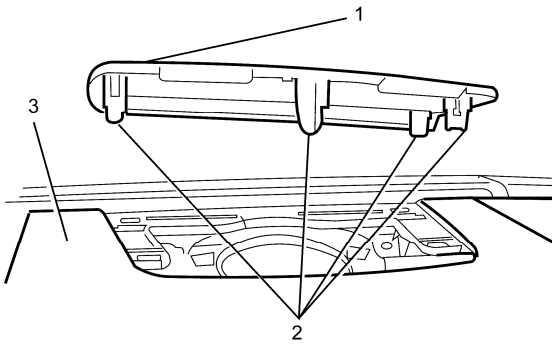

1. Disengage the I/P upper trim panel to I/P pad retainers (2) and remove the I/P upper trim panel (1) from the I/P pad (3).

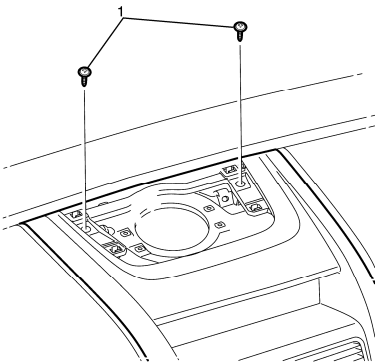

2. Remove the instrument panel center trim panel to I/P pad retaining screws (1).

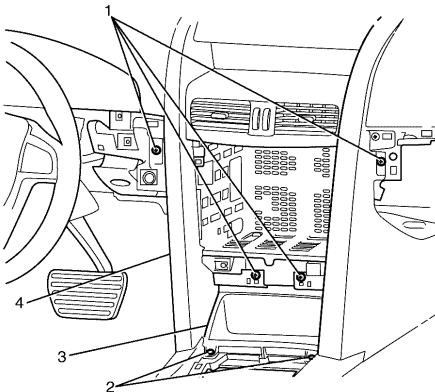

3. Remove the instrument panel center trim panel to I/P retaining screws (1).
4. Remove the instrument panel center trim panel storage bin to console retaining screws (2).
5. Remove the instrument panel center trim panel storage bin (3).
6. Disengage the instrument panel center trim panel to I/P pad retaining clips, located at the top of the center trim panel (4).
7. Lift the instrument panel center trim panel (4) upward and forward to gain access to the multi function display unit electrical connector.

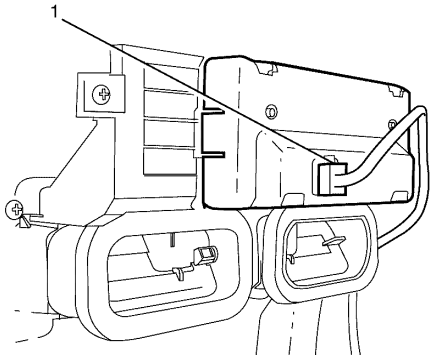

8. Disconnect the multi function display unit electrical connector (2008 only) (1) from the multi function display unit.
9. Remove the instrument panel center trim panel from the vehicle.

### Step 11. Secondary Gauges Information Display removal (2008 only)

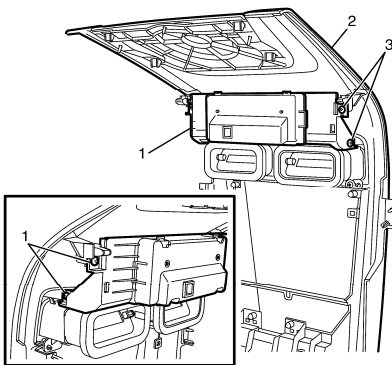

1. Remove the secondary information centre (SIC) display to I/P centre trim panel assembly retaining screws (1).
2. Remove the SIC display (2) from the I/P centre trim panel assembly (3).

### Step 12. Installing JHP sport gauges

1. Install NEW RADIO bezel (I/P centre) trim panel assembly (reverse of Step 10)



2. Install NEW gauge assembly (reverse of Step 10)
3. Route wire (1) to the white plug on the right side of the radio. Route wire (2) to the driver side grommet leading to the engine compartment

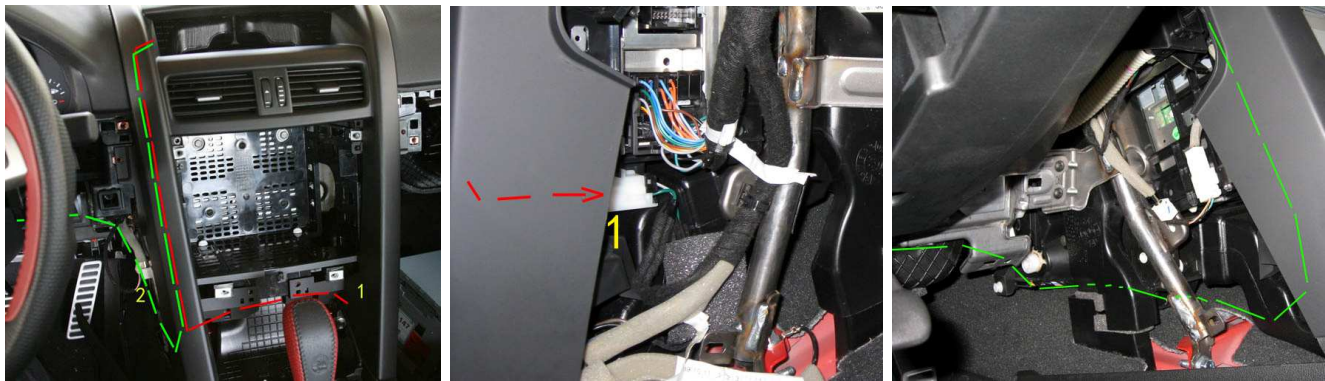

4. Punch grommet by pushing it from the engine compartment side into the interior



5. Make "X" incision in the grommet and run wire (2) through it



6. Run the wire through the hole that opened after step 5 and plug the hole with the grommet from inside of the car

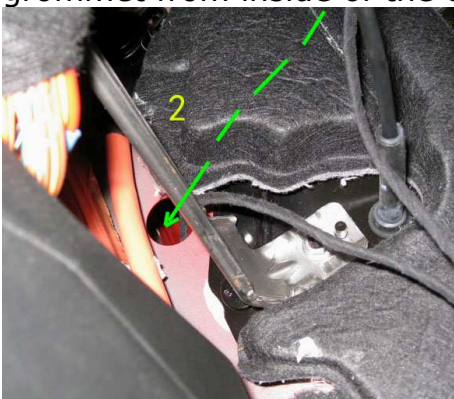

7. Run the wire along the A\C lines using zip ties, if needed to keep it away from exhaust and steering wheel column

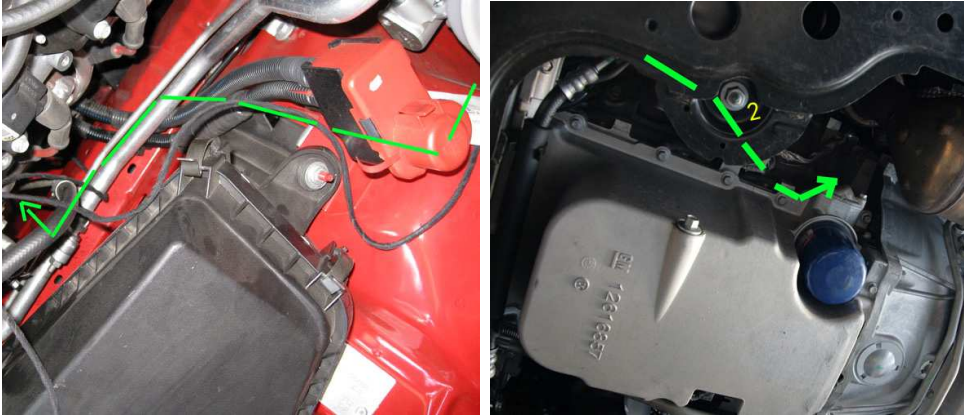

### Step 13. Installing JHP sport gauges senders/cover unit

**WARNING: UP TO 2 quarts of oil will come out during this procedure**

1. Remove factory oil plate cover that is held by 2 screws (10mm)  
**The gasket is reusable as long as the cover is removed carefully.**  
**UP TO 2 quarts of oil will come out after this step is completed**



2. Install preassembled senders/cover unit and connect wires



3. Refill engine oil
4. Start the vehicle and check for any leaks and gauge operation

### Step 14. Assemble interior of the car

1. Assemble interior using **Step 10** thru **Step 1** in reverse order

**Enjoy your new gauges!**